



**INPAQ**

# PRODUCT SPECIFICATION

DOCUMENT NO.000300XXXXXX

DESCRIPTION	DRAWN BY	DESIGNED BY	CHECKED BY	APPROVED BY
<b>MCB-S Series</b>	陳曉慧 Sharon Chen	賴柏志 Kidd Lai	賴柏志 Kidd Lai	吳維政 Albert Wu



## Chip Ferrite Bead (MCB-S Series) Engineering Spec.

This product belongs to the 3C and industrial grade standard, not for automotive application. If customer privately uses to automotive parts and results in any consequences, INPAQ is not responsible for after-sales service, thank you!

### ■ FEATURES

- **Monolithic inorganic material construction**
- **Closed magnetic circuit avoids crosstalk**
- **SMD Type & suitable for reflow and wave soldering**
- **Available in various sizes**
- **Excellent solderability and heat resistance**
- **High reliability**
- **Effectively filtering capability over a wide range of frequency**

### ■ APPLICATIONS

Filtering between analog and digital circuitry, clock generation circuitry, I/O interconnects, isolation between RF noisy circuits and logic devices susceptible to functional degradation, power supply filtering to prevent conducted RF energy from corrupting the power generation circuitry, high frequency EMI prevention of computer, printers, VCRs, TVs and portable telephones

### ■ SHAPES AND DIMENSIONS

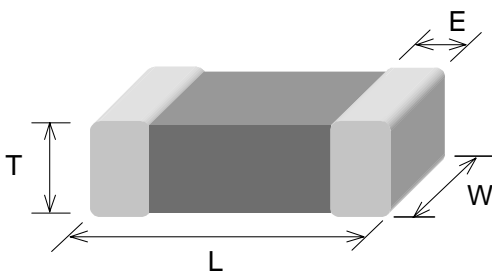

TYPE	1005 (EIA 0402)
<b>L</b>	1.00±0.10
<b>W</b>	0.50±0.10
<b>T</b>	0.50±0.10
<b>E</b>	0.25±0.10
<b>Unit</b>	mm

■ PART NUMBER CODE

MCB 1005 S 12 1 I B P DG  
 1 2 3 4 5 6 7 8 9

- 1 Series Name
- 2 Size Code: the first two digitals : length(mm), the last two digitals : width(mm)
- 3 Material Code
- 4 Impedance at 100MHz } (ex : 600=60Ω ; 121=120Ω)
- 5 Fixed Decimal Point }
- 6 Rated Current Code

A=50mA	B=80mA	C=100mA	D=150mA	E=200mA	F=300mA
G=400mA	H=500mA	I=600mA	J=700mA	K=800mA	

- 7 Soldering : Green Parts: A— Soldering Lead-Free B— Lead-Free for whole chip
- 8 Packaging : P – Paper tape, 7" reel.
- 9 INPAQ internal code

■ PART NUMBER AND CHARACTERISTICS TABLE

Part No.	Impedance(Ω) +/-25%	Test Freq. (MHz)	DCR(Ω) (Max.)	Rated Current (mA)
MCB1005S121IBPDG	120	100	0.40	600
	•Test Level : 250 mV			
<b>Test Instruments :</b>	•HP4291B RF IMPEDANCE / MATERIAL ANALYZER or EQUIVALENT •HP4338A/B MILLIOHMMETER •Agilent E5071C ENA SERIES NETWORK ANALYZER •HP6632B SYSTEM DC POWER SUPPLY			

\*\* For special part number which is not shown in the above table, please refer to appendix.

■ TAPE AND REEL SPECIFICATIONS

PAPER CARRIER

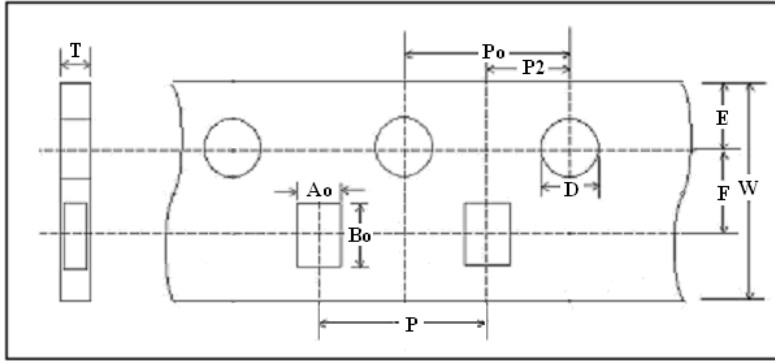

■ TAPING DIMENSIONS

Unit: mm

Size	1005
Symbol	PAPER
W	8.00±0.10
P	2.00±0.05
E	1.75±0.05
F	3.50±0.05
D	1.55±0.05
D1	NA
Po	4.00±0.10
Po10	NA
P2	2.00±0.05
Ao	0.62±0.03
Bo	1.12±0.03
Ko(T)	0.60±0.03
t	NA

■ REEL DIMENSIONS

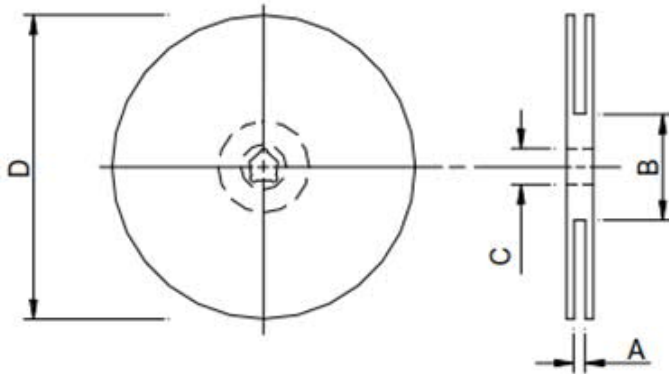

Type	7"
A(mm)	10±1.5
B(mm)	50 or more
C(mm)	13.2±1.0
D(mm)	178±2.0

7" Reel Packaging Quantity	
PART SIZE (EIA SIZE)	1005 (0402)
Qty.(pcs)	10,000
BOX	5 reels / inner box

■ RECOMMENDED SOLDERING CONDITIONS

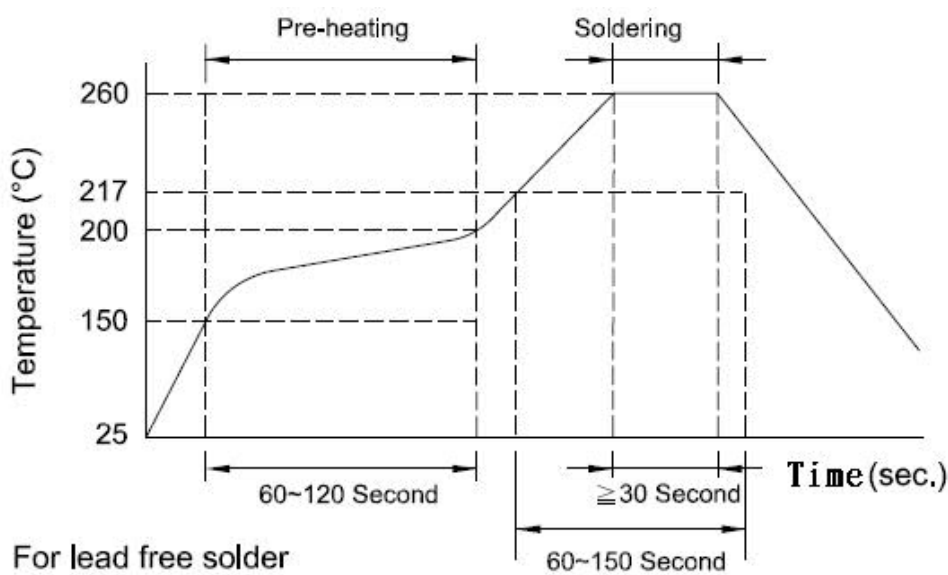

■ LAND PATTERNS FOR REFLOW SOLDERING

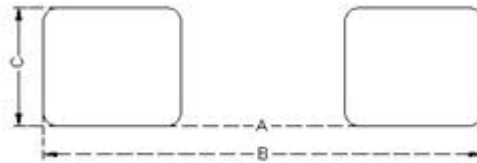

■ SOLDER LAND INFORMATION

Unit: mm (inches)

Size	A	B	C
1005	0.4 (0.016)	1.2 ~ 1.4 (0.047 ~ 0.055)	0.5 (0.020)

■ GENERAL TECHNICAL DATA

Operating temperature range : - 55°C ~ +125°C

Storage Condition : Less than 40°C and 70% RH

Storage Time: 6 months Max.

Soldering method: Reflow

■ RELIABILITY AND TEST CONDITION

Test item	Test condition	Criteria
<b>Thermal Shock</b>	a. Temperature : $-55^{\circ}\text{C} \sim +125^{\circ}\text{C}$ b. Cycle : 100 cycles c. Dwell time : 30minutes d. Measurement : at ambient temperature 24 hrs after test completion	a. No mechanical damage b. Impedance value should be within $\pm 20\%$ of the initial value
<b>Operational Life</b>	a. Temperature : $125^{\circ}\text{C} \pm 5^{\circ}\text{C}$ b. Test time : 1000 hrs c. Apply current : full rated current d. Measurement : at ambient temperature 24 hrs after test completion	a. No mechanical damage b. Impedance value should be within $\pm 20\%$ of the initial value
<b>Biased Humidity</b>	a. Temperature : $40^{\circ}\text{C} \pm 2^{\circ}\text{C}$ b. Humidity : 90 ~ 95 % RH c. Test time : 1000 hrs d. Apply current : full rated current e. Measurement : at ambient temperature 24 hrs after test completion	a. No mechanical damage b. Impedance value should be within $\pm 20\%$ of the initial value
<b>Resistance to Solder Heat</b>	a. Solder temperature : $260 \pm 5^{\circ}\text{C}$ b. Flux : Rosin c. DIP time : $10 \pm 1$ sec	a. More than 95 % of terminal electrode should be covered with new solder b. No mechanical damage c. Impedance value should be within $\pm 20\%$ of the initial value
<b>Adhesive Test</b>	a. Reflow temperature : $245^{\circ}\text{C}$ It shall be Soldered on the substrate applying direction parallel to the substrate b. Apply force(F) : 5 N c. Test time : 10 sec	a. No mechanical damage b. Soldering the products on PCB after the pulling test force $> 5$ N

Test item	Test condition	Criteria
<b>Steam Aging Test</b>	a. Temperature : 93°C b. Test time : 4 hrs c. Solder temperature : 235 ± 5°C d. Flux : Rosin e. DIP time : 5 ± 1 sec	More than 95 % of terminal electrode should be covered with new solder
<b>Rated Current Test</b>	a. Apply current : full rated current / 5min	Temperature rise should be less than 25°C



# MCB 1005S 121BP

## ELECTRICAL CHARACTERISTICS:

	Z @ 100MHz (Ohms)	DCR (Ohms)	Rated Current
Nominal	120		
Minimum	90		
Maximum	150	0.4	600mA

## PHYSICAL DIMENSIONS:

L	1.00(0.04) ±0.100(0.004)
W	0.50(0.02) ±0.100(0.004)
T	0.50(0.02) ±0.100(0.004)
E	0.25(0.01) ±0.100(0.004)

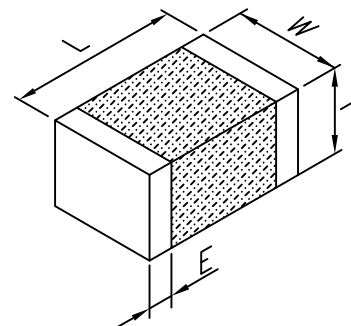

## NOTES: UNLESS OTHERWISE SPECIFIED

- 1.-All edges and corners must be rounded.
- 2.-Dimensions are in millimeters (inches)
- 3.-Taped and Reeled per current EIA specification.

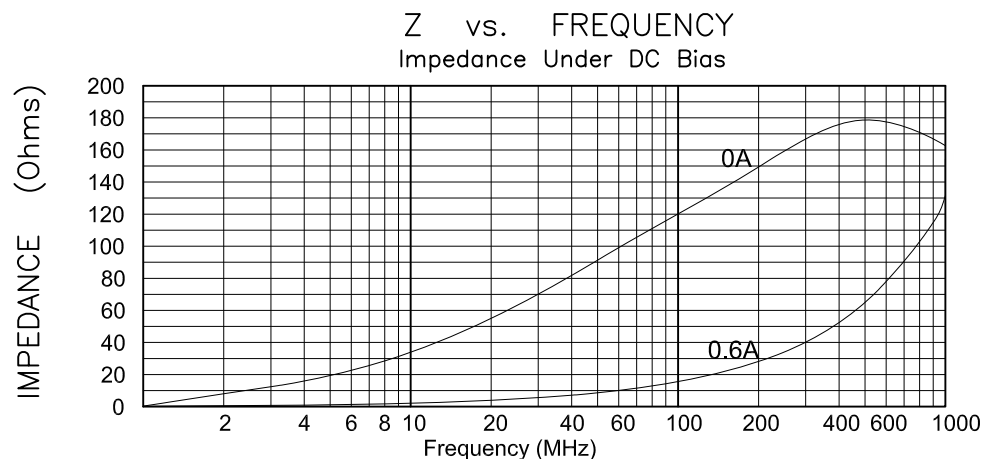
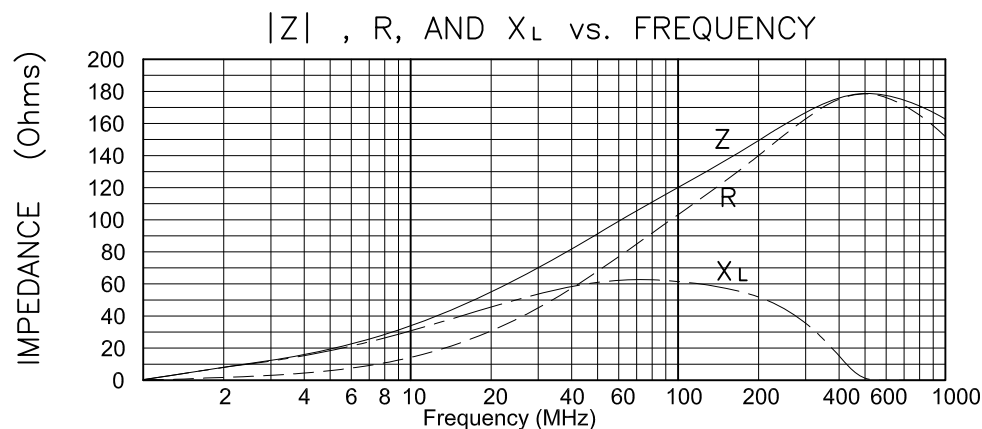

## RECOMMENDED SOLDERING CONDITIONS

### Reflow Soldering

